

OPERATOR'S, ORGANIZATIONAL AND DIRECT SUPPORT
MAINTENANCE MANUAL

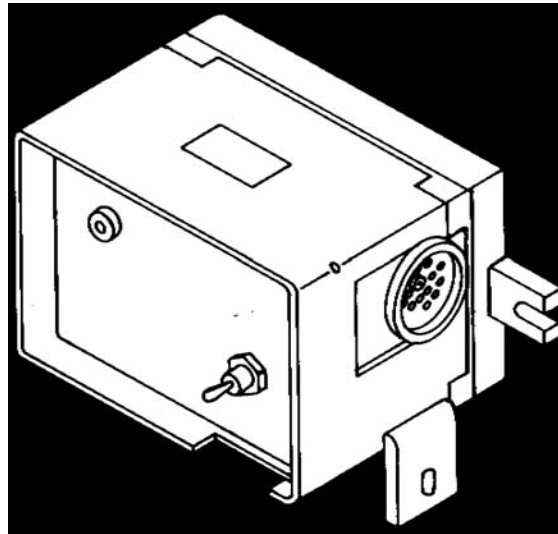

EQUIPMENT
DESCRIPTION
AND DATA

SERVICE UPON
RECEIPT AND
INSTALLATION

OPERATING
INSTRUCTIONS

OPERATOR AND
ORGANIZATIONAL
MAINTENANCE
INSTRUCTIONS

DIRECT
SUPPORT
MAINTENANCE
INSTRUCTIONS

**FILTER F-1461/VRC
(NSN 5915-01-094-5681)**

HEADQUARTERS, DEPARTMENT OF THE ARMY

21 NOVEMBER 1983



5

SAFETY STEPS TO FOLLOW IF SOMEONE IS THE VICTIM OF ELECTRICAL SHOCK

- ① **DO NOT TRY TO PULL OR GRAB THE INDIVIDUAL**
- ② **IF POSSIBLE, TURN OFF THE ELECTRICAL POWER**
- ③ **IF YOU CANNOT TURN OFF THE ELECTRICAL POWER, PULL, PUSH, OR LIFT THE PERSON TO SAFETY USING A WOODEN POLE OR A ROPE OR SOME OTHER INSULATING MATERIAL**
- ④ **SEND FOR HELP AS SOON AS POSSIBLE**
- ⑤ **AFTER THE INJURED PERSON IS FREE OF CONTACT WITH THE SOURCE OF ELECTRICAL SHOCK, MOVE THE PERSON A SHORT DISTANCE AWAY AND IMMEDIATELY START ARTIFICIAL RESUSCITATION**

WARNING

Adequate ventilation should be provided while using TRICHLOROTRIFLUOROETHANE. Prolonged breathing of vapor should be avoided. The solvent should not be used near heat or open flame; the products of decomposition are toxic and irritating. Since TRICHLORO-TRIFLUOROETHANE dissolves natural oils, prolonged contact with skin must be avoided. When necessary, use gloves that the solvent cannot penetrate. If the solvent is taken internally, consult a physician immediately.

WARNING

Compressed air shall not be used for cleaning purposes except where reduced to less than 29 pounds per square inch (psi) and then only with effective chip guarding and personnel protective equipment. Do not use compressed air to dry parts when TRICHLOROTRIFLUOROETHANE has been used. Compressed air is dangerous and can cause serious bodily harm if protective means or methods are not observed to prevent chip or particle (of whatever size) from being blown into the eyes or unbroken skin of the operator or other personnel.

Technical Manual)
)
No. 11-5915-226-13)

HEADQUARTERS
DEPARTMENT OF THE ARMY

Washington, DC, 21 November 1983

OPERATOR'S, ORGANIZATIONAL AND DIRECT SUPPORT

MAINTENANCE MANUAL

FILTER F-1461/VRC

(NSN 5915-01-094-5681)

REPORTING ERRORS AND RECOMMENDING IMPROVEMENTS

You can help improve this manual. If you find any mistakes or if you know of a way to improve the procedures, please let us know. Mail your letter, DA Form 2028 (Recommended Changes to Publications and Blank Forms), or DA Form 2028-2 located in the back of this manual direct to: Commander, US Army Communications-Electronics Command and Fort Monmouth, ATTN: DRSEL-ME-MP, Fort Monmouth, NJ 07703. In either case, a reply will be furnished direct to you.

		Paragraph	Page
	HOW TO USE THIS MANUAL.....	1	vi
CHAPTER 1.	INTRODUCTION		
Section I.	General		
	Scope	1-1	1-1
	Consolidated Index of Army Publications and Blank Forms	1-2	1-1
	Maintenance Forms, Records and Reports	1-3	1-1
	Reporting Equipment Improvement Recommendations (EIR)	1-4	1-1
	Administrative Storage	1-5	1-1
	Destruction of Army Electronics Materiel.....	1-6	1-1
	Official Nomenclature, Names, and Designations	1-7	1-1
II.	Equipment Description and Data		
	Purpose and Use.....	1-8	1-3
	Capabilities and Features	1-9	1-3
	Difference Between Models.....	1-10	1-3
	Equipment Data.....	1-11	1-3
CHAPTER 2.	SERVICE UPON RECEIPT AND INSTALLATION		
Section I.	Service Upon Receipt of Materiel		
	Unpacking	2-1	2-1
	Checking Unpacked Equipment	2-2	2-1
II.	Installation Instructions		
	Location.....	2-3	2-1
	Mounting Dimensions.....	2-4	2-1
	Cable Connections.....	2-5	2-1
CHAPTER 3.	OPERATING INSTRUCTIONS		
	Damage From Improper Settings.....	3-1	3-1
	Operator Controls and Indicators.....	3-2	3-1
	Operating Procedures	3-3	3-2

		Para	Page
CHAPTER 4.	OPERATOR AND ORGANIZATIONAL MAINTENANCE INSTRUCTIONS		
Section I.	Tools and Equipment		
	Special Tools and Test Equipment	4-1	4-1
	Materials Required	4-2	4-1
Section II.	Preventive Checks and Services		
	General.....	4-3	4-1
	Procedures	4-4	4-1
	Cleaning	4-5	4-1
	Rustproofing and Painting	4-6	4-2
Section III.	Operator and Organizational Troubleshooting		
	General Troubleshooting Procedures	4-7	4-3
	Troubleshooting Table.....	4-8	4-3
Section IV.	Organizational Maintenance		
	Removal of F–1461/VRC	4-9	4-6
	Replacement of F–1461/VRC	4-10	4-6
	Operational Test.....	4-11	4-6
CHAPTER 5.	FUNCTIONING OF EQUIPMENT		
	General.....	5-1	5-1
	Schematic Analysis	5-2	5-1
CHAPTER 6.	DIRECT SUPPORT MAINTENANCE INSTRUCTIONS		
Section I.	General		
	Color Codes	6-1	6-1
	Voltage Measurements	6-2	6-1
	Resistance Measurements	6-3	6-2
	Tools, Materials, and Test Equipment.....	6-4	6-2
Section II.	Troubleshooting and Maintenance		
	Direct Support Troubleshooting	6-5	6-3
	Troubleshooting Table.....	6-6	6-3
Section III.	Maintenance		
	Parts Replacement Techniques.....	6-7	6-6
	Replacement of Indicator Lamp	6-8	6-6
	Removal and Installation of Electronic Component Assembly	6-9	6-6
	Disassembly of F–1461/VRC.....	6-10	6-6
	Reassembly of F–1461 VRC.....	6-11	6-6

		Para	Page
Section IV.	Direct Support Test Procedures		
	General.....	6-12	6-9
	Physical Inspection Chart.....	6-13	6-9
	Continuity Test.....	6-14	6-10
	Zener Overvoltage Protection.....	6-15	6-10
	Power On-Off Control Test	6-16	6-12
APPENDIX A.	REFERENCES		A-1
B.	MAINTENANCE ALLOCATION		
Section I.	Introduction		B-1
II.	Maintenance Allocation Chart.....		B-4
III.	Tools and Test Equipment Requirements.....		B-5
IV.	Remarks		B-5
APPENDIX C.	COMPONENTS OF END ITEM AND BASIC ISSUE ITEMS		
Section I.	Introduction		C-1
II.	Components of End Item.....		C-2
III.	Basic Issue Items.....		C-2
APPENDIX D.	ADDITIONAL AUTHORIZATION ITEMS (Not applicable)		
APPENDIX E.	EXPENDABLE SUPPLIES AND MATERIALS LIST		
Section I.	Introduction		E-1
II.	Expendable Supplies and Materials List		E-2

LIST OF ILLUSTRATIONS

<u>Figure</u>	<u>Title</u>	<u>Page</u>
1-1	Filter F-1461/VRC	1-2
2-1	Typical Installation.....	2-2
2-2	Installation Dimensions	2-2
3-1	Controls and Indicators.....	3-1
4-1	F-1461/VRC Removal.....	4-6
4-2	F-1461/VRC Installation	4-7
5-1	F-1461/VRC Schematic Diagram	5-2
6-1	Indicator Lamp Removal and Replacement	6-7
6-2	Electronic Component Assembly Replacement.....	6-7
6-3	F-1461/VRC - Exploded View	6-8
6-4	Bench Test Set-Up	6-11
FO-1	Color Code Marking for Military Standard Resistors and Inductors (Sheet 1 of 2).....	
FO-1	Color Code Marking for Military Standard Resistors and Inductors (Sheet 2 of 2).....	

LIST OF TABLES

<u>Table</u>	<u>Title</u>	<u>Page</u>
1-1	List of Nomenclatures.....	1-2
1-2	Equipment Data.....	1-3
3-1	Controls, Indicators, and Connectors	3-2
4-1	Organizational Preventive Maintenance Checks and Services	4-2
4-2	Operator and Organizational Troubleshooting Procedures.....	4-4
6-1	Voltage Readings.....	6-1
6-2	Resistance Readings.....	6-2
6-3	Direct Support Troubleshooting.....	6-4

HOW
TO USE
THIS MANUAL

- This technical manual covers maintenance procedures for use by operator, organizational and direct support level repair personnel to maintain the F-1461/VRC.
- The F-1461/VRC is designed for connection with AM-1780/VRC and C-2298/VRC or C-2299/VRC as part of Intercommunications Set AN/VIC-1 when cabling is routed through turret sliprings.
- You must have supporting manuals for other components of the system on hand for proper maintenance.
- Carefully follow all the cautions and warnings in this manual.

CHAPTER 1 INTRODUCTION

Section I. GENERAL

1-1. Scope

This manual covers Filter F-1461/VRC (fig. 1-1) hereafter referred to as the F-1461/VRC. The manual provides instructions for installation, operation and maintenance for operator, organizational and direct support repair personnel.

1-2. Consolidated Index of Army Publications and Blank Forms

Refer to the latest issue of DA Pam 310-1 to determine whether there are new editions, changes or additional publications pertaining to the equipment.

1-3. Maintenance Forms, Records, and Reports

a. Reports of Maintenance and Unsatisfactory Equipment. Department of the Army forms and procedures used for equipment maintenance will be those prescribed by TM 38-750. The Army Maintenance Management System (TAMMS).

b. Report of Packaging and Handling Deficiencies. Fill out and forward SF 364 (Report of Discrepancy (ROD)) as prescribed in AR 735-11-2/DLAR 4140.55/NAVMATINST 4355.73A/AFR 400.54/MCO 4430.3F.

c. Discrepancy in Shipment Report (DISREP) (SF 361). Fill out and forward Discrepancy in Shipment Report (DISREP) (SF 361) as prescribed in AR 55-38/NAVSUPINST 4610.33C/AFN 75-18/MCO P4610.19D/DLAR 4500.15.

1-4. Reporting Equipment Improvement Recommendations (EIR)

If your F-1461/VRC needs improvements, let us know. Send us an EIR. You, the user, are the only one who can tell us what you don't like about the design. Put it on an SF 368 (Quality Deficiency Report). Mail it to Commander, US Army Communications-Electronics Command and Fort Monmouth, ATTN: DRSEL-ME-MP, Fort Monmouth, New Jersey 07703. We'll send you a reply.

1-5. Administrative Storage

Administrative storage of equipment issued to and used by the Army activities will have preventive maintenance performed in accordance with the PMCS charts before storing. When removing the equipment from administrative storage the PMCS should be performed to assure operational readiness.

1-6. Destruction of Army Electronics Materiel

Destruction of Army electronics materiel to prevent enemy use shall be in accordance with TM 750-244-2.

1-7. Official Nomenclature, Names, and Designations

Refer to table 1-1 for nomenclatures covered in this manual.

Table 1-1. List of Nomenclatures

Designation	Model/Equipment
<p>AN/VIC-1</p> <ul style="list-style-type: none"> • AM-1780/VRC • C-2297/VRC • C-2298/VRC • CX-9640/VR • CX-4723/VRC • F-1461/VRC 	<p>Intercommunication Set consisting of:</p> <p>Amplifier, Audio Frequency Control, Intercommunications Set</p> <p>Control, Intercommunications Set</p> <p>Cable, Power, Electrical</p> <p>Cable, Power, Electrical</p> <p>Filter</p>

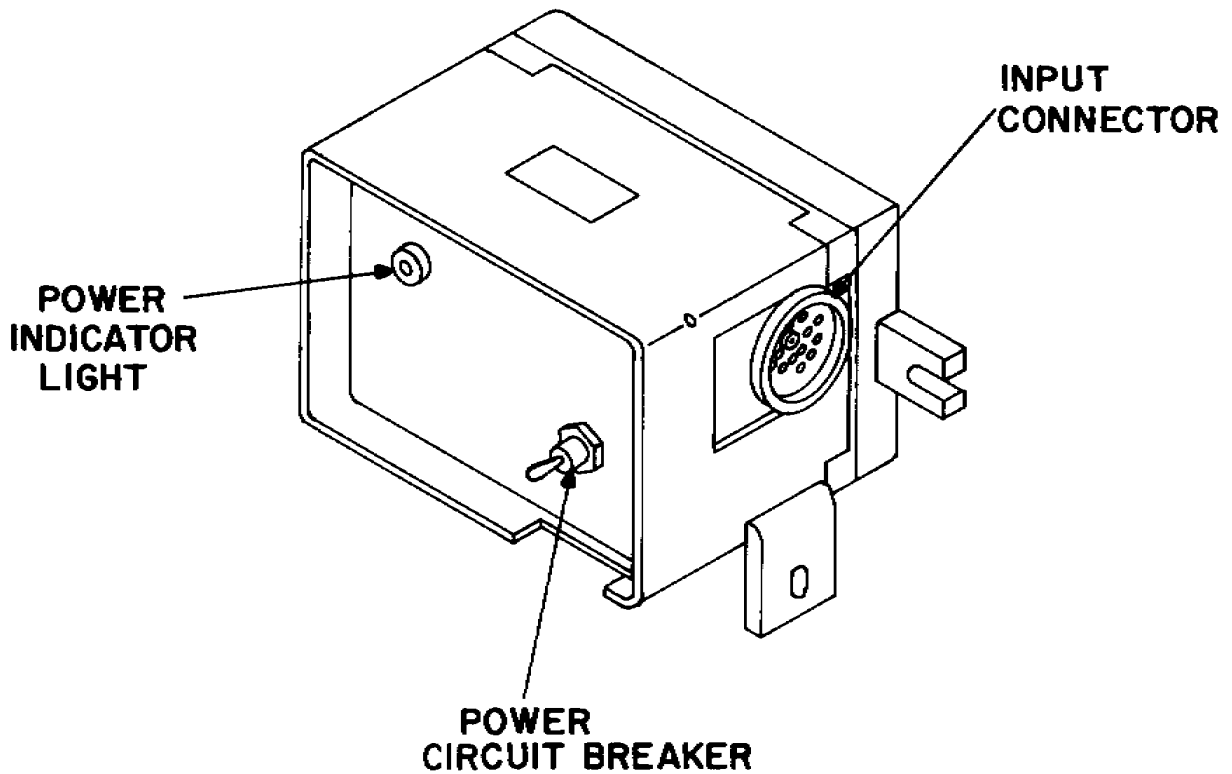

Figure 1-1. Filter F-1461/VRC.

Section II. EQUIPMENT DESCRIPTION AND DATA

1-8. Purpose and Use

a. Purpose. Filter F-1461/VRC is a power line ripple filter designed for certain tracked vehicle installation, such as Howitzer M-109A.

b. Use. F-1461/VRC is used with Intercommunications Set AN/VIC-1 connecting to Amplifier, Audio Frequency AM-1780/VRC and Control, Intercommunications Set C-2297/VRC or C-2298/VRC to provide a filtered 24 V dc power source.

a. Filtering of the 25.5 V dc power from the turret sliprings to C-2298/VRC and C-2299/VRC.

b. Interconnection of signal and control circuit between turret sliprings and C-2298/VRC or C-2299/VRC.

1-10. Differences Between Models

This publication covers only one model, F-1461/VRC, which is part of Modification Filter Kit, MK-2008/VRC.

1-9. Capabilities and Features

1-11. Equipment Data

Equipment data for F-1461/VRC are listed in table 1-2.

The F-1461/VRC provides the following.

Table 1-2. Equipment Data

Model No:	F-1461/VRC
Input power requirements:	
Voltage	25.5 V dc, unfiltered, maximum 1 ampere
Source	AM-1780/VRC through the turret sliprings
Physical characteristics:	
Weight	2-1/2 pounds
Dimensions:	
Width:	6 inches
Height:	4 inches
Depth:	3-1/4 inches
Material	Die cast aluminum.
Mounting	Two mounting lugs; drilled for 5/16 inch bolt mounting, on 5-1/2 inch centers, may also be mounted by two 1/4 inch bolts spaced 4-1/2 inches apart.

Table 1-2. Equipment Data – Continued

Output characteristics:	
Voltage	25.5 V dc filtered.
Service	Connects to C-2297/VRC or C-2298/VRC.
Operating ambient Temperature:	-50 deg. F (45.6 deg C) to + 125 deg. F (51.6 deg. C).

CHAPTER 2 SERVICE UPON RECEIPT AND INSTALLATION

Section I. SERVICE UPON RECEIPT OF MATERIEL

2-1. Unpacking

The F-1461/VRC is shipped in a cardboard carton to protect the unit against damage. When unpacking the F-1461/VRC observe the following instructions:

- a. Unpack the F-1461/VRC carefully to keep from damaging the unit.
- b. Visually inspect the unit for any damage which may have occurred in transit. Save the carton and protective cushioning in case the unit eventually requires reshipment.

2-2. Checking Unpacked Equipment

- a. Inspect the equipment for damage in-

curred during shipment. If the equipment has been damaged, report the damage on SF 364 (para 1-3).

- b. Check the equipment against appendix C and the packing slip to see if the shipment is complete. Report all discrepancies in accordance with paragraph 1-3.

- c. Check to see if the equipment has been modified. (Equipment which has been modified will have the MWO number on the cover.) Check also to see if all currently applicable MWO's have been applied. (Current MWO's applicable to the equipment are listed in DA Pam 310-1.)

Section II. INSTALLATION INSTRUCTIONS

2-3. Location

(fig. 2-1)

- a. Figure 2-1 is a typical installation in a tracked vehicle. The F-1461/VRC connects between Audio Frequency Amplifier AM-1780/VRC and Intercommunication Control Set C-2297/VRC or C-2298/VRC. Refer to the technical manual covering Intercommunication Set AN/VIC-1 for further installation instructions.

- b. Installation hardware is supplied with original packing for mounting the F-1461/VRC (appx C).

2-4. Mounting Dimensions

(fig. 2-2)

Figure 2-2 provides mounting dimensions for the F-1461/VRC.

2-5. Cable Connections

- a. Input (J72). Cable assembly CX-9640/VRC connects to 24 V dc unfiltered at turret sliprings.

- b. Output (J71). Cable Assembly CX-4723/VRC connects to the intercommunications control set.

- c. Remove connector dust caps prior to attaching cables.

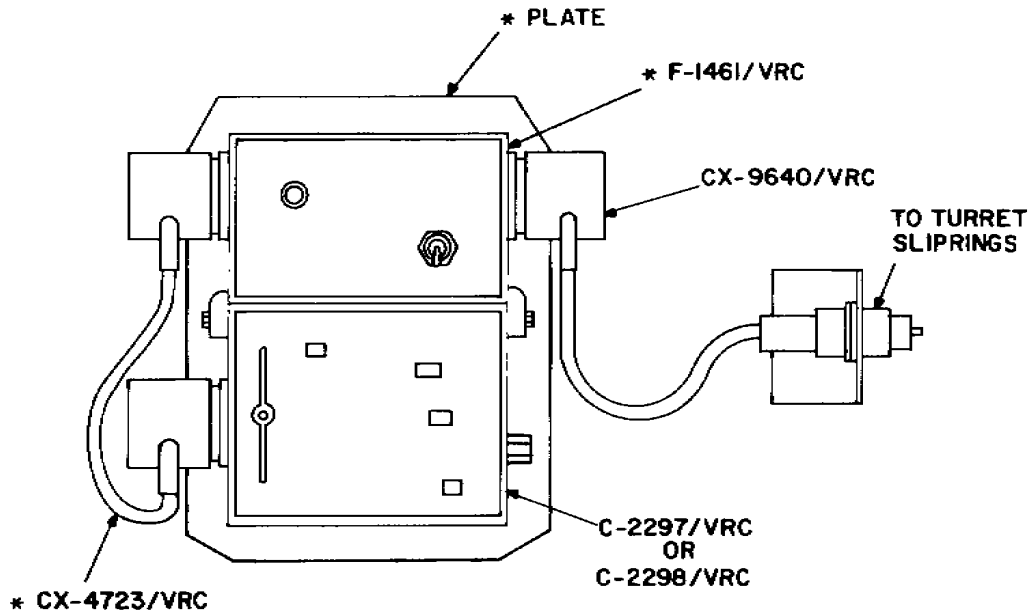

* PART OF MODIFICATION FILTER KIT MK-2008/VRC NSN 5820-00-532-0994.

Figure 2-1. Typical Installation.

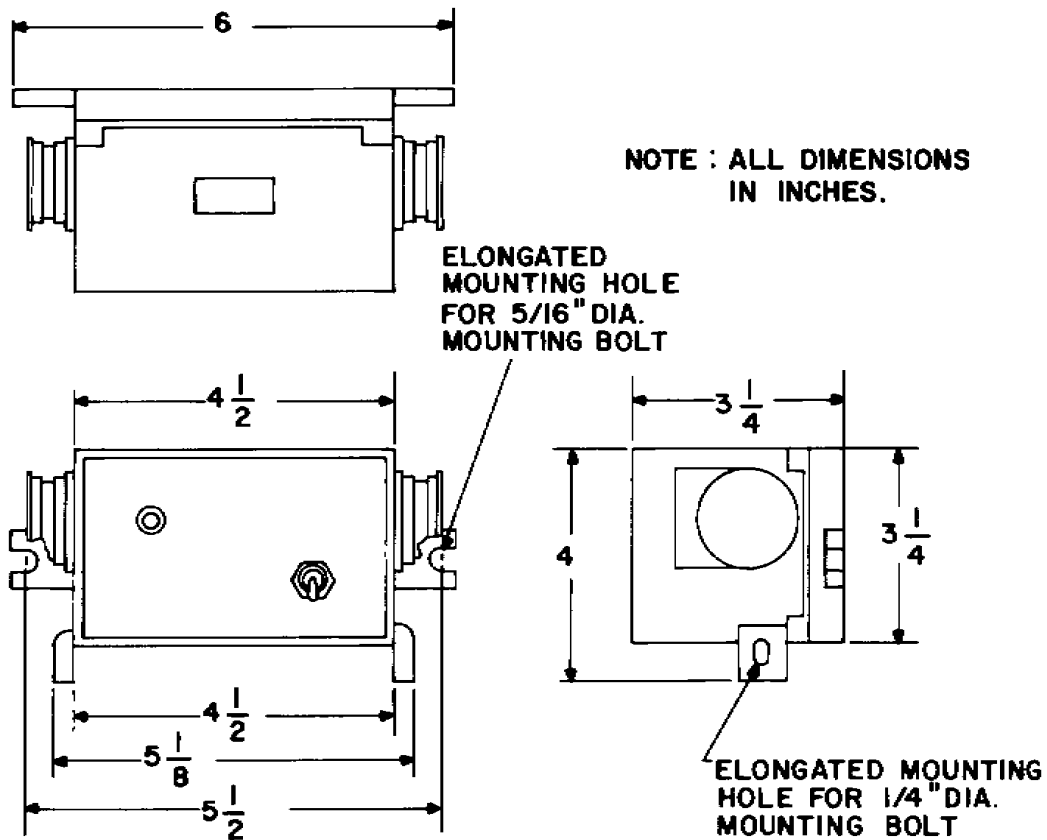

Figure 2-2. Installation Dimensions.

CHAPTER 3 OPERATING INSTRUCTIONS

3-1. Damage From Improper Settings

There are no restrictions on control settings.
No damage can occur to the equipment.

3-2. Operator Controls and Indicators

See figure 3-1 and table 3-1 for location and operation of the POWER CIRCUIT BREAKER, POWER indicator, and connectors J72 IN and J71 OUT.

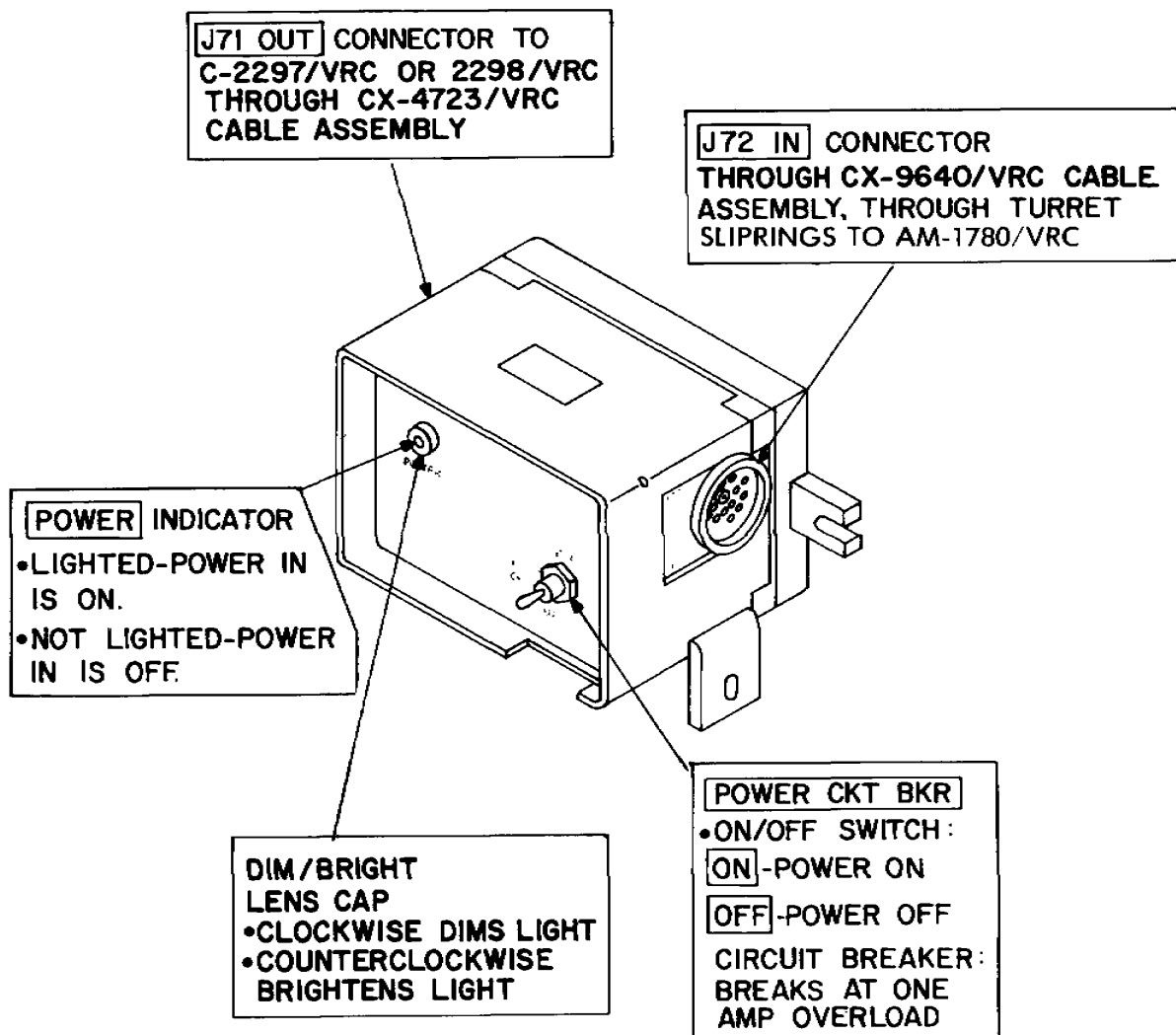

Figure 3-1. Controls and Indicators.

Table 3-1. Controls, Indicators, and Connectors

Controls and Indicator	Function
J72 IN connector	Input connector – from turret sliprings.
J71 OUT connector	Output connector – to C-2297/VRC and C-2298/VRC.
POWER CKT BKR	ON-OFF switch and circuit protection.
POWER indicator light	When lighted indicates POWER CIRCUIT BREAKER is set ON. Turn the lens cap clockwise to DIM; counterclockwise to BRIGHT.

3-3. Operating Procedures

a. Starting Procedures (fig. 3-1). Apply power to the F-1461/VRC by setting the POWER CIRCUIT BREAKER to the ON position. The POWER indicator light should go

on. Adjust the light dimmer control as needed.

b. Turn-off Procedure (fig 3-1). Set the POWER CIRCUIT BREAKER to the OFF position. The POWER indicator light should go OFF.

CHAPTER 4 OPERATOR AND ORGANIZATIONAL MAINTENANCE INSTRUCTIONS

Section I. TOOLS AND EQUIPMENT

4-1. Special Tools and Test Equipment

Refer to the maintenance allocation chart, appendix B, for the tools and equipment used at organizational maintenance level.

4-2. Materials Required

The following maintenance materials are re-

quired for operator and organizational maintenance:

- a. Soft brush (item 1, appx E).
- b. Lint-free cloth (item 2, appx E).
- c. Zinc chromate primer (item 4, appx E).
- d. Forest green enamel (item 5, appx E).

Section II. PREVENTIVE MAINTENANCE CHECKS AND SERVICES

4-3. General

Preventive maintenance is the systematic care, servicing, and inspection of equipment to prevent the occurrence of trouble, reduce downtime and assure that the equipment is serviceable.

a. Systematic Care. The procedures given in paragraph 4-4 and 4-5 cover the systematic care essential to proper upkeep and operation of the F-1461/VRC.

b. Preventive Maintenance Service and Inspection. The preventive maintenance checks and services table 4-1 outline inspections to be made at specific intervals. These inspections are made to maintain equipment in good operating condition. Records and reports of these inspections must be made in accordance with TM 38-750.

4-4. Procedures

Table 4-1 specifies checks and services that must be accomplished before, during and after operation, weekly and monthly or under the special circumstances listed below.

- a. When the F-1461/VRC is initially installed.
- b. When the F-1461/VRC is reinstalled after relocation for any reason.
- c. At least once each week if equipment is maintained in a standby condition.

4-5. Cleaning

Inspect the exterior of the equipment. The exterior surface must be free of dust, dirt, grease and fungus.

- a. Remove dust and loose dirt with a clean, soft brush.

Table 4-1. Organizational Preventive Maintenance Checks and Services

W – Weekly Q – Quarterly A – Annually
 M – Monthly S – Semiannually B – Biannually

Item No.	Interval						Item to be Inspected	Procedures	For readiness reporting, equipment is not ready/available if:
	W	M	Q	S	A	B			
1	X						Installation	Check to see that equipment is properly installed.	Operation is impaired.
2	X						Operational Check	Give the F-1461/VRC an operation check following paragraph 3-3.	Operation is impaired.

WARNING

Adequate ventilation should be provided while using TRICHLOROTRIFLUOROETHANE. Prolonged breathing of vapor should be avoided. The solvent should not be used near heat or open flame; the products of decomposition are toxic and irritating. Since TRICHLOROTRIFLUOROETHANE dissolves natural oils, prolonged contact with skin must be avoided. When necessary, use gloves that the solvent cannot penetrate. If the solvent is taken internally, consult a physician immediately.

b. Remove grease, fungus and ground-in dirt from equipment using a cloth dampened (not wet) with trichlorotrifluoroethane.

c. Clean cable connectors with trichlorotrifluoroethane. Male contacts should be wiped with the same solution. Female contacts should be cleaned in the same way, using a soft brush.

4-6. Rustproofing and Painting

a. Rustproofing. When the finish on the F-1461/VRC has become badly scarred or damaged, rust and corrosion can be prevented by touching up the bare spots. Use No. 000 sandpaper to clean the surface down to bare metal. Obtain a bright smooth finish.

b. Painting. Apply primer; after drying, brush two thin coats of paint on the bare metal to protect it. Refer to the applicable cleaning and refinishing practices specified in TB 746-10.

Section III. OPERATOR AND ORGANIZATIONAL TROUBLESHOOTING

4-7. General Troubleshooting Procedures

a. General. Troubleshooting procedures for the F-1461/VRC are based on the normal operation of the equipment being used. When an abnormal indication is observed note the symptom and use the troubleshooting chart in this chapter to identify the probable cause.

b. Visual Inspection.

(1) Before troubleshooting, inspect the equipment for visible defects. This saves repair time and may prevent further damage. Inspect the following for obvious defects.

- (a) The seating of all connectors.

- (b) Cracked or broken cables.

- (c) Equipment completeness.

(2) If visual inspection does not locate the trouble, proceed to troubleshooting table 4-2.

4-8. Troubleshooting Table

Table 4-2 is a troubleshooting table for use at operator and organizational level. Use the symptom index to locate the malfunction paragraph. Follow the instruction given in the corrective column when the problem has been identified. If recommended solutions do not correct the problem, a higher category of maintenance is required.

Table 4-2. Operator and Organizational Troubleshooting Procedures

MALFUNCTION	TEST OR INSPECTION	CORRECTIVE MEASURES
<p>1. POWER INDICATOR WILL NOT LIGHT</p> <p>Step 1. Check if POWER CIRCUIT BREAKER is set to ON; if not:</p> <p style="padding-left: 100px;">Set to ON. If circuit breaker breaks again, higher level of maintenance is required. Replace the F-1461/VRC (para 4-9 and 4-10).</p> <p>Step 2. Check security of input/output connectors.</p> <p style="padding-left: 100px;">Tighten loose connections.</p> <p>Step 3. If POWER CIRCUIT BREAKER is set ON and POWER INDICATOR lamp does not light.</p> <p style="padding-left: 100px;">Turn dimmer cap counterclockwise to brighten.</p> <p style="padding-left: 100px;">If lamp does not light, and is not defective, higher level of maintenance is required.</p>		

Table 4-2. Operator and Organizational Troubleshooting Procedures –
Continued

<p>MALFUNCTION</p> <p>TEST OR INSPECTION</p> <p>CORRECTIVE MEASURES</p>
<p>2. SIGNAL/CONTROL CIRCUIT(S) FAULTY</p> <p>Step 1. Check security of input/output cabling and connectors.</p> <p style="padding-left: 100px;">Tighten loose connections.</p> <p>Step 2. Check for proper operation of interconnecting units (AM-1780/VRC, C-2297/VRC, or C-2298/VRC).</p> <p style="padding-left: 100px;">Refer to AN/VIC-1 technical literature.</p> <p>Step 3. If steps 1 or 2 do not correct the trouble:</p> <p style="padding-left: 100px;">Higher level of maintenance is required. Replace the F-1461/VRC (para 4-9 and 4-10).</p>

Section IV. ORGANIZATIONAL MAINTENANCE

4-9. Removal of F-1461/VRC
(fig. 4-1)

Refer to figure 4-1 to replace the F-1461/VRC.

4-10. Replacement of F-1461/VRC
(fig. 4-2)

Refer to figure 4-2 to install the F-1461/VRC.

4-11. Operational Test

Operational test of the F-1461/VRC requires check out of the unit during operating procedures set forth in paragraph 3-3.

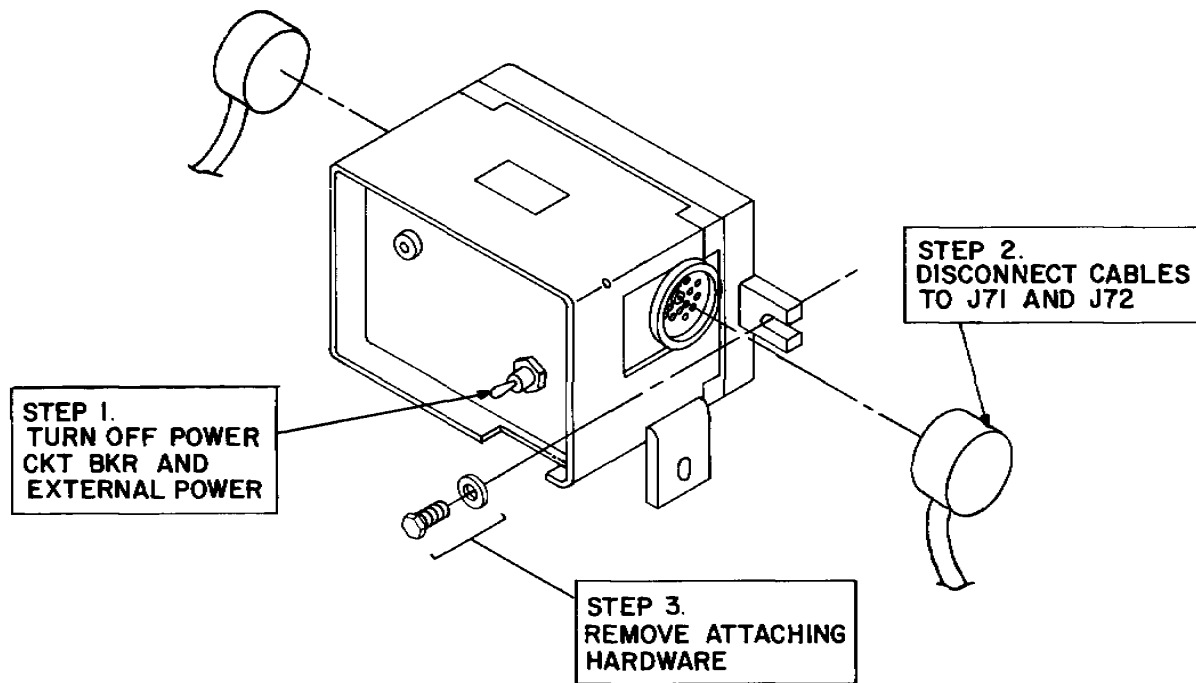

Figure 4-1. F-1461/VRC Removal.

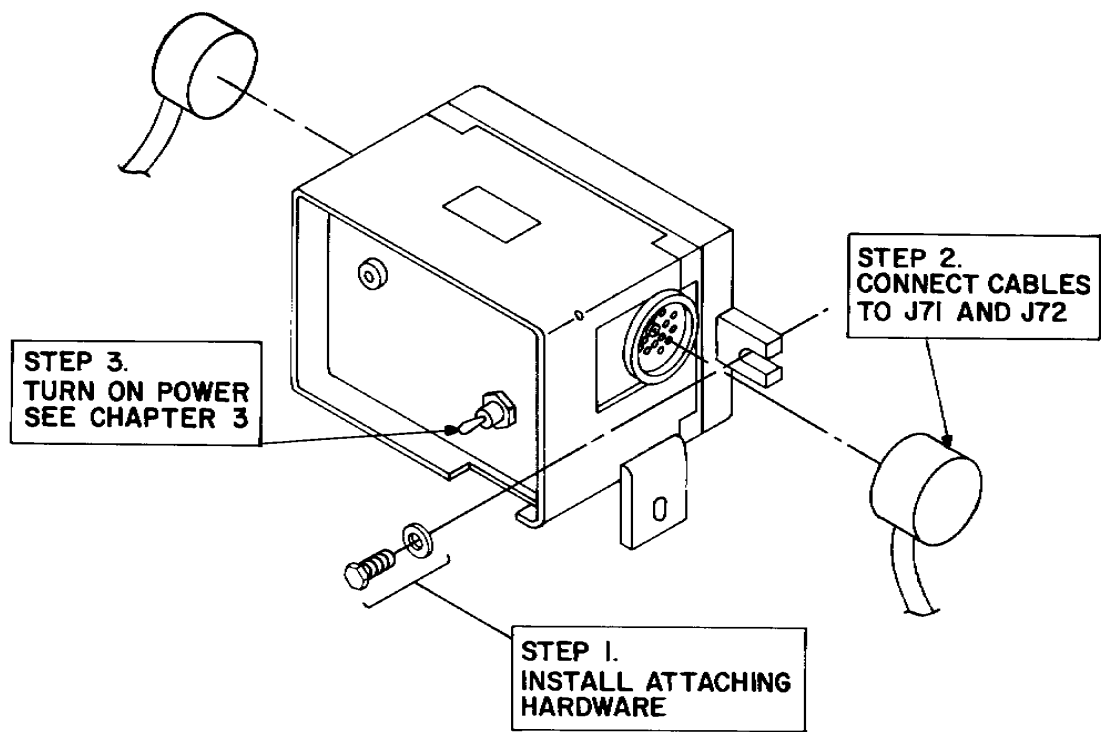

Figure 4-2. F-1461/VRC Installation.

CHAPTER 5 FUNCTIONING OF EQUIPMENT

5-1. General

The F-1461/VRC is a powerline ripple filter intended for use with Intercommunications Control Sets C-2297/VRC and C-2298/VRC as part of Intercommunication Set AN/VIC-1. Typical uses are for tracked vehicle installation when audio and power cabling is routed through turret sliprings. In addition to power line filtering of 25.5 V dc between AM-1780/VRC and C-2297/VRC or C-2298/VRC it provides interconnection facilities of signal/control circuits between these units.

5-2. Schematic Analysis (fig. 5-1)

a. Input power of +25.5 V dc vehicular source, is applied to pin C of J72 IN; terminal A

is grounded. A standard power supply capacitor input PI network filter circuit is used to decrease ripple present in the input, Zener diode CR1 acts to clip voltage transients at 36 V dc +2 volts. Circuit breaker CB1 protects the circuit at 1 ampere. Power indicator lamp DS1 lights when power is present at the input side of F-1461/VRC. Filtered output power of +25.5 V dc +0 -15 V dc is presented at pin C of J71 OUT.

b. Pins B, D, E, F, H, J through N, P, and R through V of J72 IN carry signal and control voltages from AM-1780/VRC through the turret sliprings to respective pins of J71 OUT of F-1461/VRC for connection to C-2297/VRC or C-2298/VRC.

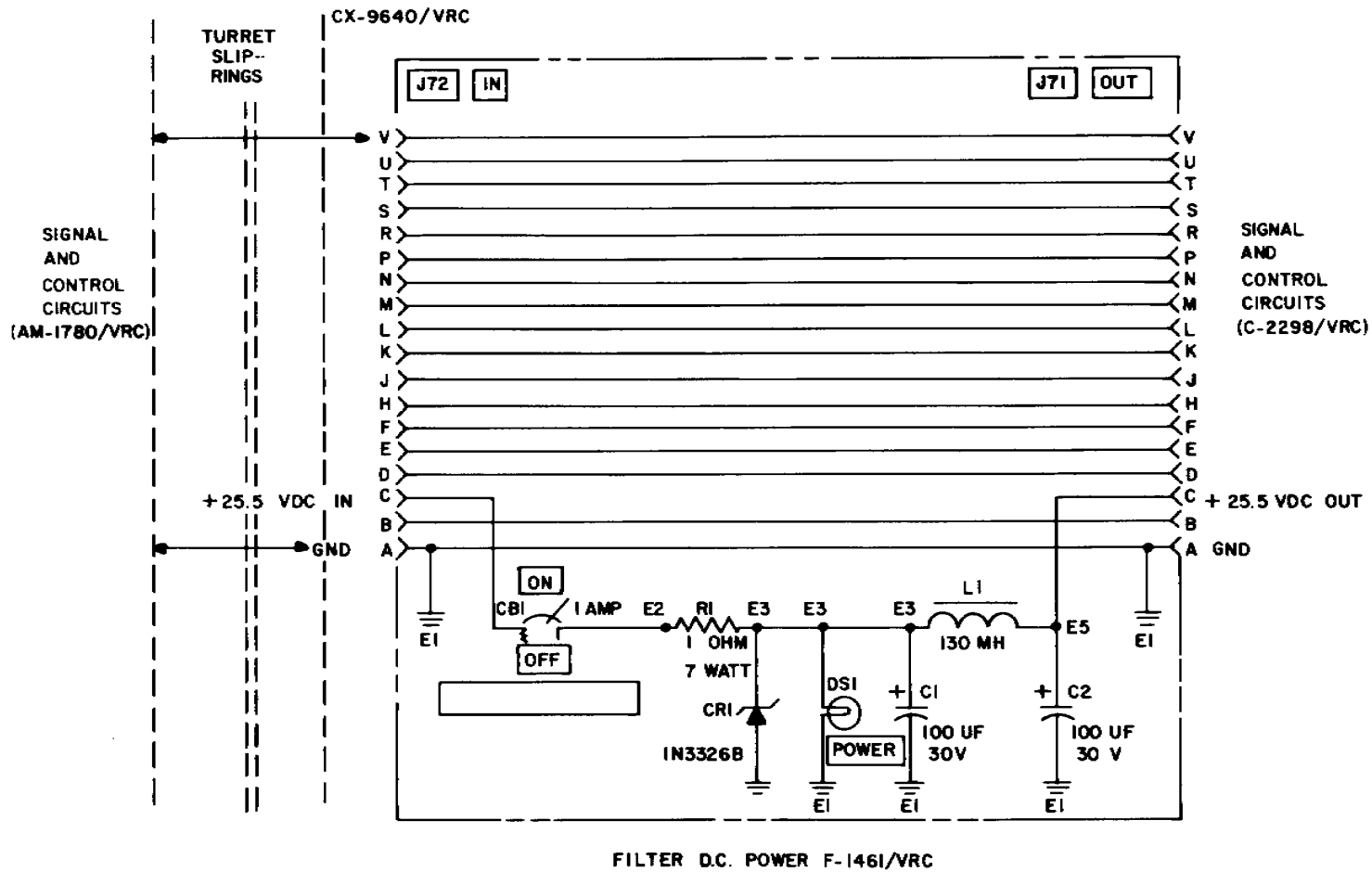

Figure 5-1. F-1461/VRC Schematic Diagram.

CHAPTER 6 DIRECT SUPPORT MAINTENANCE INSTRUCTIONS

Section I. GENERAL

6-1. Color Codes

set up shown in figure 6-4.

Color codes for standard resistors, inductors, and capacitors are shown in figure FO-1.

WARNING

Be careful when making voltage measurements. Use insulated test probes and do not touch any internal part of the F-1461/VRC while it is energized.

6-2. Voltage Measurements

The voltage readings given in table 6-1 are made at connectors J71 and J72 using the test

Table 6-1. Voltage Readings

Test prods		Indication	Test condition
negative	positive	(volts dc)	
Ground	J72-C	+50.0	Circuit breaker ON or OFF (fig 6-4).
Ground	J71-C	0	Circuit breaker OFF (fig 6-4).
Ground	J71-C	36.0 ±2.0	Circuit breaker ON (fig 6-4).
Ground	J72-C	25.5	Circuit breaker OFF (fig 6-4).
Ground	J71-C	0	Circuit breaker OFF (fig 6-4).
Ground	J71-C	25.5 +0	Circuit breaker ON (fig 6-4).
		-1.5	Circuit breaker ON (fig 6-4).

6-3. Resistance Measurements

F-1461/VRC disconnected from the vehicle communication system.

The resistance readings given in table 6-2 are made at connectors J71 and J72 with the

Table 6-2. Resistance Readings

Test Prods		Resistance	Test Condition
Negative	Positive	(ohms)	
Ground	J72-C	Infinity	Circuit breaker OFF
Ground	J71-C	80 +10 ohms	Circuit breaker OFF
Ground	J72-C	70 ±10 ohms	Circuit breaker ON
Ground	J71-C	80 ±10 ohms	Circuit breaker ON
J72-C	J71-C	13 ±2 ohms	Circuit breaker ON
J72-C	J71-C	Infinity	Circuit breaker OFF

6-4. Tools, Materials, and Test Equipment

The following tools, materials, and test equipment are required for maintenance, troubleshooting and repair:

a. Tool Kit, Electronic Equipment TK-100/G.

b. Multimeter TS-352B/U.

c. Power supply (50 V dc).

d. Resistor 270 ohm, 5 watt.

Section II. TROUBLESHOOTING AND MAINTENANCE

6-5. Direct Support Troubleshooting

Troubleshooting at direct support level includes all the techniques outlined for operator's and organizational maintenance level and any special or additional techniques required to isolate a defective part. This usually requires removal of the unit from the vehicle to a shop area where bench testing can be conducted.

a. General. The first step in servicing a defective F-1461/VRC is to sectionalize the fault. Sectionalization means tracing the fault to the input or output portion of the unit. The second step is to localize the fault. Localization means tracing the fault to a defective circuit responsible for the condition. Some faults, such as burned-out components, arcing, and shorted wiring; can often be located by sight, smell and sound. The majority of faults however, must be isolated by checking voltages and resistances.

b. Sectionalization and Localization. The tests given in (1) and (2) below will reduce unnecessary work and aid in tracing trouble in a defective F-1461/VRC. The F-1461/VRC is a single unit and is theoretically divided into several sections for convenience in troubleshooting as power distribution wiring, power indicator circuit and signal distribution wiring.

(1) Visual inspection. The purpose of visual inspection is to locate faults without testing or measuring circuits. All components should be observed and an attempt made to sectionalize and localize the fault to a particular part.

(2) Operational test. Use an operational test to identify the general location of trouble. In many instances, the test will help in determining the exact nature of the fault. The operational procedure given in paragraph 3-3,

with the normally expected indications called out in the procedures provide good operational tests.

(3) Troubleshooting table. The troubleshooting table 6-1 lists symptoms of common trouble and gives the corrective measures or references. The table cannot include all trouble symptoms that may occur; therefore, the technician should use this table as a guide in analyzing symptoms that may not be listed.

(4) Component locations. Figures 6-1, 6-2 and 6-3 show component locations on the F-1461/VRC.

6-6. Troubleshooting Table

Table 6-3 outlines procedures for localizing troubles within the various circuits of the unit. Refer to figure 6-3 for parts location. Refer to the overall schematic diagram (fig. 5-1) to identify circuit components. Depending on the nature of the operational symptoms, one or more of the localizing procedures will be necessary. When the trouble has been localized to a particular circuit use voltage and resistance measurements to isolate the trouble to a particular part.

d. Use of Troubleshooting Table 6-3. When an abnormal symptom is observed in the equipment, look for a description of the symptom in the malfunction column, and perform the corrective action given in corrective action column.

e. Conditions for Test. All checks outlined in the troubleshooting table 6-3 are to be conducted with the F-1461/VRC and under power and operating.

Table 6-3. Direct Support Troubleshooting Procedures

MALFUNCTION
TEST OR INSPECTION
CORRECTIVE ACTION
<p>1. POWER INDICATOR LAMP WILL NOT LIGHT</p> <p>Step 1. Check if POWER CIRCUIT BREAKER is set to ON. If not: Set to ON.</p> <p>Step 2. If POWER CIRCUIT BREAKER is set to ON and POWER INDICATOR LAMP does not light.</p> <p style="padding-left: 40px;">Check for faulty lamp; replace a faulty lamp (para 6-8).</p> <p style="padding-left: 40px;">Check for faulty lampholder; replace a faulty lampholder (para 6-10).</p> <p style="padding-left: 40px;">Check for faulty circuit breaker; replace a faulty circuit breaker (para 6-10).</p> <p style="padding-left: 40px;">Check wiring through power circuit (fig. 5-1). Repair wiring.</p> <p style="padding-left: 40px;">Check for faulty electronic component assembly; replace faulty assembly (para 6-9).</p>

Table 6-3. Direct Support Troubleshooting Procedures - Continued

MALFUNCTION	TEST OR INSPECTION	CORRECTIVE ACTION
2. CIRCUIT BREAKER WILL NOT SET	Step 1. Check for faulty circuit breaker.	Replace a faulty circuit breaker (para 6-10).
	Step 2. Check wiring through power circuit (para 6-14).	Repair wiring.
	Step 3. Check for faulty electronic components assembly (para 6-9).	Replace faulty electronic components assembly (para 6-9).
3. POWER CIRCUITRY FAULTY	Step 1. Check for faulty circuit breaker.	Replace faulty circuit breaker (para 6-10).
	Step 2. Check wiring through power circuit (para 6-14).	Repair wiring.
	Step 3. Check for faulty electronic components assembly (para 6-10).	Replace faulty electronic components assembly (para 6-10).
4. SIGNAL/CONTROL CIRCUIT(S) FAULTY	Step 1. Check input/output cabling and connectors.	Repair cabling/connectors as needed.
	Step 2. Check operation of Interconnection Units AM-1780/VRC, C-2297/VRC, C-2298/VRC.	Refer to AN/VIC-1 technical literature TM 11-5830-340-12.
	Step 3. Check internal wiring of F-1461/VRC for breaks or shorts (para 6-14).	Repair wiring as needed.

Section III. MAINTENANCE

6-7. Parts Replacement Techniques

The majority of parts comprising the F-1461/VRC are accessible when the top cover is removed. The electronic component assembly (para 6-9) contains the circuit components for filtering the DC supply. This assembly is to be replaced when faulty.

WARNING

Shutdown system power to the F-1461/VRC before starting work. Do not work on live circuits.

a. Special instructions for the removal and replacement of the electronic component assembly is in paragraph 6-9. When removing parts or repairing wiring, tag leads and mark terminals for positive identification before disconnecting any wiring to assure proper reconnection. When wiring is replaced, use wire that conforms with the original wire size and marking. Most parts can be reinstalled by remounting them in their original locations with the original hardware and reconnecting the leads.

CAUTION

Remove and install components that are soldered with a pencil-type soldering iron having a 25-watt maximum capacity. If the soldering iron must be used with ac voltage use an isolating transformer between the soldering gun; damaging voltages can be induced in the circuits components.

b. Make well soldered connections; a carelessly soldered joint may create a new trouble, and is one of the most difficult problems to isolate. Be careful not to allow drops of solder to fall into the equipment; this action may cause short circuits.

6-8. Replacement of Indicator Lamp (fig. 6-1)

Refer to figure 6-1 to remove and replace the indicator lamp.

6-9. Removal and Installation of Electronic Component Assembly (fig. 6-2)

Refer to figure 6-2 to remove and install the electronic component assembly.

6-10. Disassembly of F-1461/VRC (fig. 6-3)

Refer to figure 6-3 to disassemble the filter.

6-11. Reassembly of F-1461/VRC (fig. 6-3)

a. Refer to figure 6-3 to reassemble the filter.

b. Check the cover gasket for distortion or loss of resiliency. Replace a damaged or dead gasket.

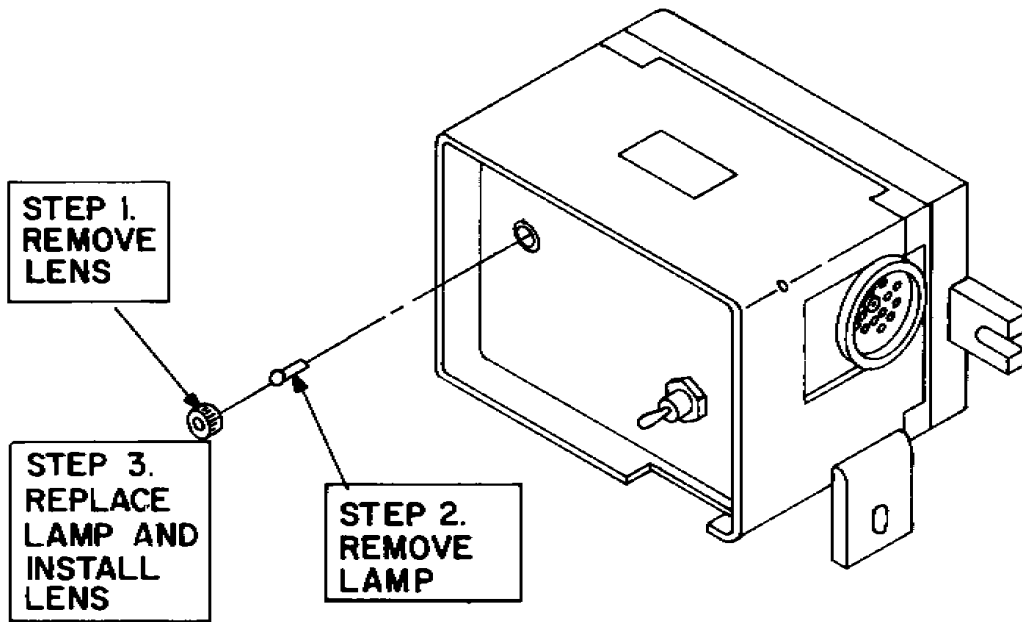

Figure 6-1. Indicator Lamp Removal and Replacement.

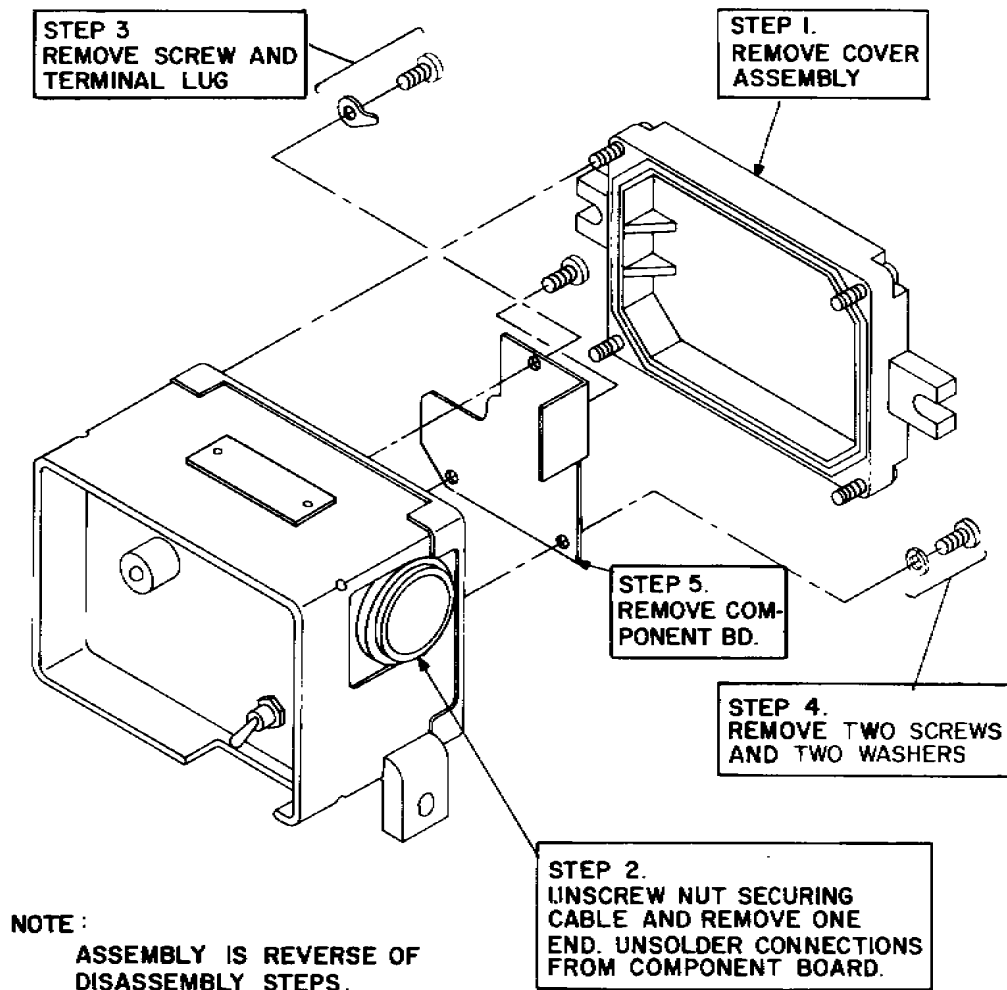
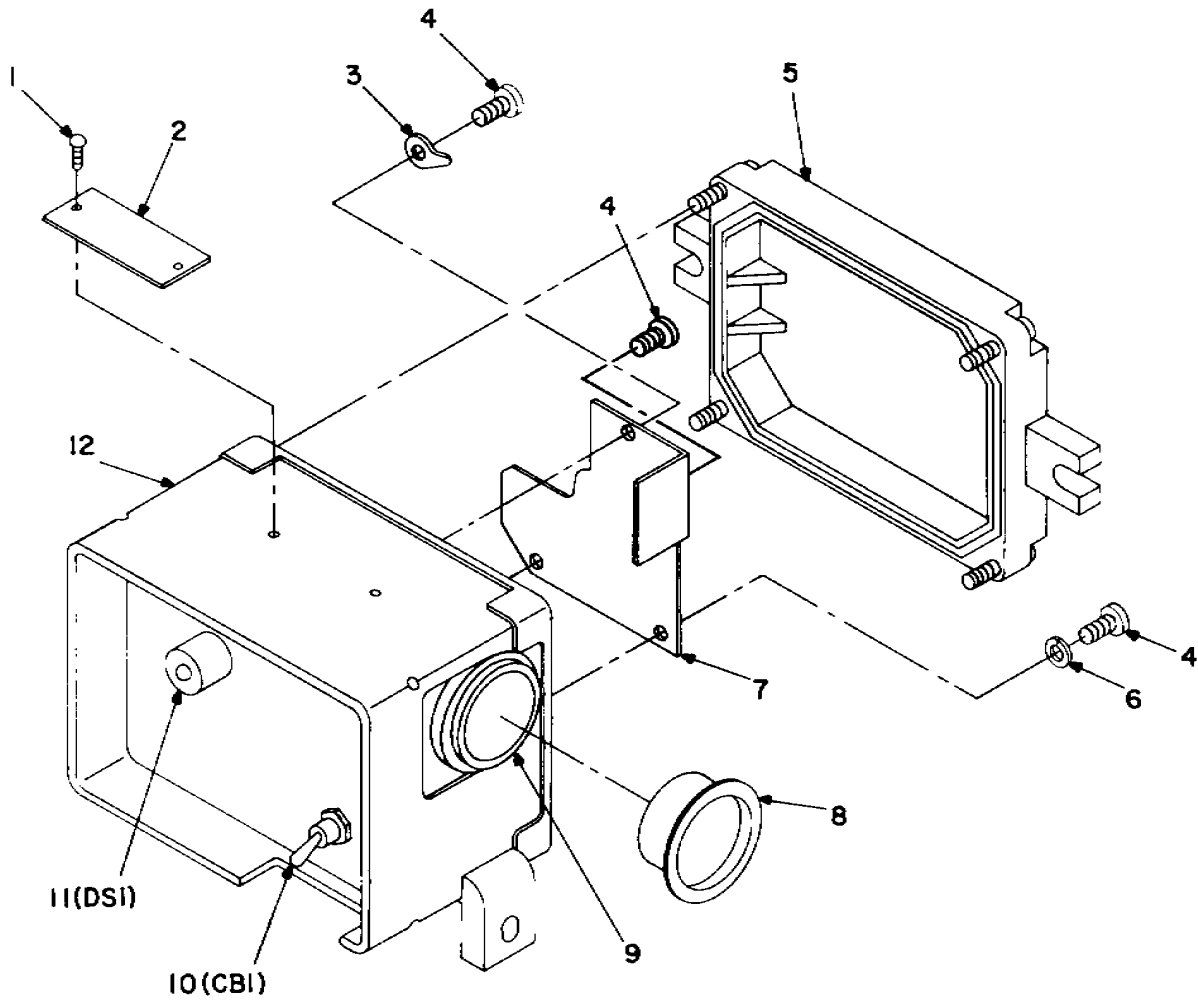

Figure 6-2. Electronic Component Assembly Replacement.



- | | |
|-------------------|----------------------|
| 1. DRIVE SCREW | 7. ELECT CMPT ASSY |
| 2. IDENT PLATE | 8. DUST CAP |
| 3. TERMINAL LUG | 9. WIRE HARNESS ASSY |
| 4. MACHINE SCREW | 10. CIRCUIT BREAKER |
| 5. COVER ASSEMBLY | 11. INDICATOR LIGHT |
| 6. LOCKWASHER | 12. HOUSING ASSEMBLY |

Figure 6-3. F-1461/VRC—Exploded View.

Section IV. DIRECT SUPPORT TEST PROCEDURES

6-12. General

This section provides instructions for direct support personnel to determine the operational readiness of a F-1461/VRC that has been repaired.

These instructions take the form of physical tests and inspections as well as operational tests. The performance standards specified for these must be successfully obtained before a unit can be considered serviceable.

6-13. Physical Inspection Chart

Tasks		Results
1	<p>Inspect top cover and housing For damage, missing parts, and conditions of paint.</p> <p style="text-align: center;">NOTE Touchup painting is recommended instead of refinishing whenever practical; screwheads, binding posts, receptacles, and other plated parts will not be painted or polished with abrasives.</p>	<p>No damage evident or parts missing. External surfaces to be painted show bare metal. External lettering is legible.</p>
2	<p>Inspect top cover for loose or missing screws.</p>	<p>All screws are tight; none are missing.</p>
3	<p>Inspect connectors and wiring for looseness or damage.</p>	<p>No loose parts or damage.</p>

6-14. Continuity Test

INITIAL SETUP

Test Equipment

Multimeter TS-352B/U

Equipment Conditions

1. Remove the F-1461/VRC from the vehicle.
2. No connections are made to J71 to J72.
3. Power circuit breaker to be in either position.

List of Tasks

Task No.	Task	Performance Standard
1	Measure continuity between all corresponding pins of J71 and J72 with the exception of pin C.	No open circuits between all corresponding pins.
2	Measure continuity between pin A and all other pins of both J71 and J72.	There shall be an open circuit on all measurements.

6-15. Zener Overvoltage Protection Test

INITIAL SETUP

Test Equipment

Power Supply 50 V dc
 Multimeter TS-352B/U
 Resistor, 270 ohms, 5 watt

Equipment Condition

1. Connect the equipment as shown in figure 6-4A.

List of Tasks

Task No.	Task	Performance Standard
1	Apply 50 V dc to J72 pins C(+) and A(-).	None.
2	Set POWER CIRCUIT BREAKER to ON.	None.
3	Measure open circuit voltage at J71 pins C(+) and A (-).	The voltage shall be less than 38 V dc.

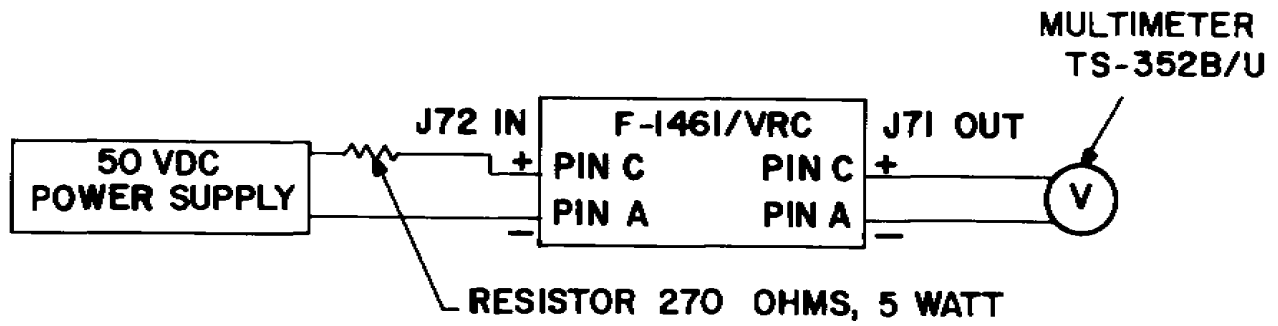

A. ZENER OVERVOLTAGE PROTECTION TEST

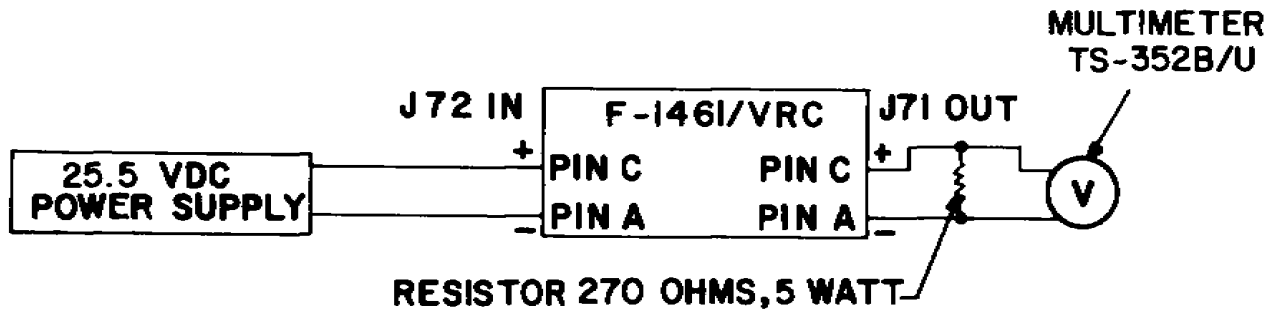

B. POWER ON-OFF CONTROL TEST

Figure 6-4. Bench Test Set-Up.

6-16. Power On-Off Control Test

INITIAL SETUP

Test Equipment

- Power Supply 50 V dc
- Multimeter TS-352B/U.
- Resistor, 270 ohms, 5 watt

Equipment Condition

1. Connect the equipment as shown in figure 6-4B.

List of Tasks

Task No.	Task	Performance Standard
1	Apply 25.5 V dc to J72 pins C(+) and A(-).	None
2	Set POWER CIRCUIT BREAKER to ON.	See step 3 and 4.
3	Observe the voltage at output receptacle J71 pins C(+) and A(-).	Voltage of 25.5 +0 -1.5 V dc shall be present at output.
4.	Observe the POWER indicator lamp and operate the POWER CIRCUIT BREAKER to ON and OFF position.	The light shall go on and off with operation of the circuit breaker.

APPENDIX A REFERENCES

DA Pam 310-1	Consolidated Index of Army Publications and Blank Forms.
SB 11-573	Painting and Preservation Supplies Available for Field Use for Electronic Command Equipment.
TB 746-10	Field Instructions for Painting and Preserving Electronic Command Equipment.
TM 9-213	Painting Instructions for Field Use.
TM 11-5830-340-12	Operator's and Organizational Maintenance Manual (Including Repair Parts and Special Tools List) Intercommunication Set AN/VIC-1.
TM 11-5915-226-23P	Organizational and Direct Support Maintenance Repair Parts and Special Tools List (Including Depot Maintenance Repair Parts and Special Tools) for Filter F-1461/VRC (NSN 5915-01-094-5681).
TM 38-750	The Army Equipment Record System and Procedures
TM 750-244-2	Procedures for Destruction of Electronics Materiel to Prevent Enemy Use (Electronics Command).

APPENDIX B MAINTENANCE ALLOCATION

Section I. INTRODUCTION

B-1. General

This appendix provides a summary of the maintenance operations for the F-1461/VRC. It authorizes categories of maintenance for specific maintenance functions on repairable items and components and the tools and equipment required to perform each function. This appendix may be used as an aid in planning maintenance operations.

B-2. Maintenance Functions

Maintenance functions will be limited to and defined as follows:

- a. Inspect. To determine the serviceability of an item by comparing its physical, mechanical, and/or electrical characteristics with established standards through examination.
- b. Test. To verify serviceability and to detect incipient failure by measuring the mechanical or electrical characteristics of an item and comparing those characteristics with prescribed standards.
- c. Service. Operation required periodically to keep an item in proper operating condition, i.e., to clean (decontaminate), to preserve, to drain, to paint, or to replenish fuel, lubricants, hydraulic fluids, or compressed air supplies.
- d. Adjust. To maintain, within prescribed limits, by bringing into proper or exact position, or by setting the operating characteristics to the specified parameters.
- e. Align. To adjust specified variable elements of an item to bring about optimum or desired performance.
- f. Calibrate. To determine and cause corrections to be made or to be adjusted on instruments or test measuring and diagnostic equipments used in precision measurement. Consists of comparisons of two instruments, one of which is a certified standard of known accuracy, to detect and adjust any discrepancy in the accuracy of the instrument being compared.
- g. Install. The act of emplacing, seating, or fixing into position an item, part, or module (component or assembly), in a manner to allow the proper functioning of the equipment or system.
- h. Replace. The act of substituting a serviceable like type part, subassembly, or module (component or assembly) for an unserviceable counterpart.
- i. Repair. The application of maintenance services (inspect, test, service, adjust, align, calibrate, replace) or other maintenance actions (welding, grinding, riveting, straightening, facing, remachining, or resurfacing) to restore serviceability to an item by correcting specific damage, fault, malfunction, or failure in a part, subassembly, module (component or assembly), end item, or system.
- j. Overhaul. That maintenance effort (service/action) necessary to restore an item to a completely serviceable/operational condition as prescribed by maintenance standards (i.e., DMWR) in appropriate technical publications. Overhaul is normally the highest degree of maintenance performed by the Army. Overhaul does not normally return an item to like new condition.

k. Rebuild. Consists of those services/actions necessary for the restoration of un-serviceable equipment to a like new condition in accordance with original manufacturing standards. Rebuild is the highest degree of materiel maintenance applied to Army equipment. The rebuild operation includes the act of returning to zero those age measurements (hours, miles, etc.) considered in classifying Army equipments/components.

B-3. Column Entries

a. Column 1, Group Number. Column 1 lists group numbers, the purpose of which is to identify components, assemblies, subassemblies, and modules with the next higher assembly.

b. Column 2, Components/Assembly. Column 2 contains the noun names of components, assemblies, subassemblies and modules for which maintenance is authorized.

c. Column 3, Maintenance Functions. Column 3 lists the functions to be performed on the item listed in column 2. When the items are listed without maintenance functions, it is solely for the purpose of having the group numbers in the MAC and RPSTL coincide.

d. Column 4, Maintenance Category. Column 4 specifies, by the listing of a work time figure in the appropriate subcolumn(s), the lowest level of maintenance authorized to perform the function listed in column 3. This figure represents the active time required to perform that maintenance function at the indicated category of maintenance. If the number of complexity of the tasks within the listed maintenance function vary at different maintenance categories, appropriate work time figures will be shown for each category. The number of task-hours specified

by the work time figures represents the average time required to restore an item (assembly, sub-assembly, components, module, end item or system) to a serviceable condition under typical operation conditions. This time includes preparation time, troubleshooting time and assurance/quality control time in addition to the time required to perform the specific tasks identified for the maintenance function authorized in the maintenance allocation chart. Subcolumns of column 4 are as follows:

- C - Operator/Crew
- O - Organizational
- F - Direct Support
- H - General Support
- D - Depot

e. Column 5, Tools and Equipment. Column 5 specifies by code, those common tool sets (not individual tools) and special tools, test, and support equipment required to perform the designated function.

f. Column 6, Remarks. Column 6 contains an alphabetic code which leads to the remarks in Section IV, Remarks, which is pertinent to the item opposite the particular code.

B-4. Tool and Test Equipment Requirements (Sect. III)

a. Tool or Test Equipment Reference Code. The numbers in this column coincide with the numbers used in the tools and equipment column of the MAC. The numbers indicate the applicable tools or test equipment for the maintenance functions.

b. Maintenance Category. The codes in this column indicate the maintenance category allocated the tool or test equipment.

c. Nomenclature. This column lists the noun name and nomenclature of the tools and test equipment required to perform the maintenance functions.

d. National/NATO Stock Number. This column lists the National/NATO stock number of the specific tool or test equipment.

e. Tool Number. This column lists the manufacturer's part number of the tool followed by the Federal Supply Code for manufacturers (5-digit) in parentheses.

B-5. Remarks

a. Reference Code. This code refers to the appropriate item in Section II, column 6.

b. Remarks. This column provides the required explanatory information necessary to clarify items appearing in section II.

**SECTION II. MAINTENANCE ALLOCATION CHART
FOR
FILTER F-1461/VRC**

(1) Group Number	(2) Component Assembly	(3) Maintenance Functions	(4) Maintenance Category					(5) Tools and Equip.	(6) Remarks
			C	O	F	H	D		
00	FILTER, F-1461/VRC	Inspect Install Test Test Replace Repair Replace	0,1	0.4 0.2 0.4 0.1	0.5 0.5			1 2,3,4 1	A
01	Electronic Component Assembly	Replace			0.4			1	B

**SECTION III. TOOL AND TEST EQUIPMENT REQUIREMENTS
FOR
FILTER F-1461/VRC**

Tool or Test Equipment Ref Code	Maintenance Category	Nomenclature	National/NATO Stock Number	Tool Number
1	O	TOOL KIT, ELECTRONIC EQUIPMENT TK-101/G	5180-00-064-5178	
2	F	TOOL KIT, ELECTRONIC EQUIPMENT TK-100/G	5180-00-605-0079	
3	F	POWER SUPPLY, PP3514/U	6130-00-445-6933	
4	F	MULTIMETER, TS-352B/U	6625-00-553-0142	
5	F	RESISTOR, 270 OHMS, 3 WATT RW7/4S2710		

**SECTION IV. REMARKS
FOR
FILTER F-1461/VRC**

Tool or Test Equipment Ref Code	Maintenance Category	Nomenclature	National/NATO Stock Number	Tool Number
1	O	TOOL KIT, ELECTRONIC EQUIPMENT TK-101/G	5180-00-064-5178	
2	F	TOOL KIT, ELECTRONIC EQUIPMENT TK-100/G	5180-00-605-0079	
3	F	POWER SUPPLY, PP3514/U	6130-00-445-6933	
4	F	MULTIMETER, TS-352B/U	6625-00-553-0142	
5	F	RESISTOR, 270 OHMS, 3 WATT RW7/4S2710		

APPENDIX C

COMPONENTS OF END ITEMS AND BASIC ISSUE ITEMS LIST

Section I. INTRODUCTION

C-1. Scope

This appendix lists components of end items and basic issue items for the F-1461/VRC to help you inventory items required for safe and efficient operation.

C-2. General

The Components of End Item and Basic Issue Items Lists are divided into the following sections:

a. Section II. Components of End Item.

This listing is for informational purposes only, and is not authority to requisition replacements. These items are part of the end item, but are removed and separately packaged for transportation and shipment. As part of the end item, these items must be with the end item whenever it is issued or transferred between property accounts. Illustrations are furnished to assist you in identifying the item.

b. Section III. Basic Issue Items. These are the minimum essential items required to place the F-1461/VRC in operation, to operate it, and to perform emergency repairs. Although shipped separately packaged, BII must be with the F-1461/VRC during operation and whenever it is transferred between property accounts. The illustration will assist you with hard-to-identify items. This manual is your authority to

request/requisition replacement BII, based on TOE/MTOE authorization of the end item.

C-3. Explanation of Columns

The following provides an explanation of columns found in the tabular listings:

a. Column (1) - Illustration Number. (Illustration Number). This column indicates the number of the illustration in which the item is shown.

b. Column (2) - National Stock Number. Indicates the National stock number assigned to the item. The national stock numbers in section III will be used for requisitioning basic issue items.

c. Column (3) - Description. Indicates the National item name and, if required, a minimum description to identify and locate the item. The last line for each item indicates the FSCM (in parentheses) followed by the part number.

d. Column (4) - Unit of Measure (U/M). Indicates the measure used in performing the actual operational/maintenance function. This measure is expressed by a two-character alphabetical abbreviation (e.g., ea. in, pr).

e. Column (5) - Quantity Required (Qty Rqd). Indicates the quantity of the item authorized to be used with/on the equipment.

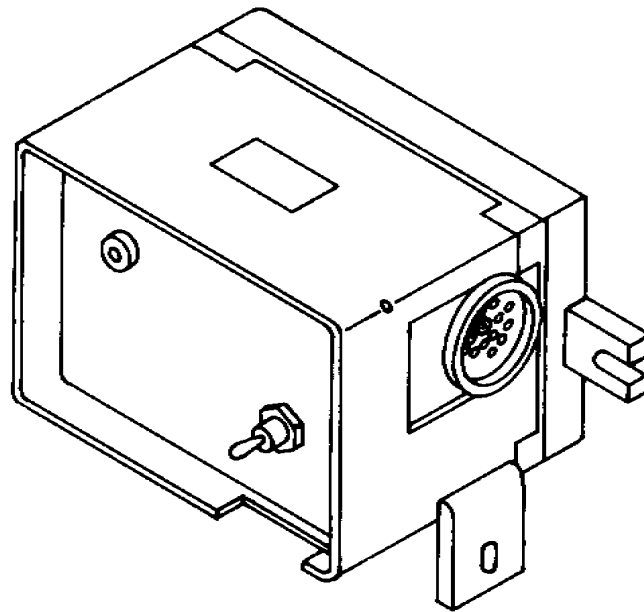

SECTION II. COMPONENTS OF END ITEM

(1) ILLUS NO.	(2) NATIONAL STOCK NUMBER	(3) DESCRIPTION (FSCM) AND PART NUMBER	(4) U/M USABLE ON CODE	(5) QTY REQD
	5915-01-094-5681	FILTER, SC-D-951290 (80058) F-1461/VRC	EA	1
		INSTALLATION HARDWARE KIT (80063) SC-B-951299 CONSISTING OF:	EA	1
		CAP SCREW, HEX (96906) MS90726-34	EA	3
		CAP SCREW, HEX (96906) MS90726-6	EA	3
		HEX NUT, PLAIN (96906) MS35690-522	EA	3
		LOCKWASHER (96906) MS45904-68	EA	3
		LOCKWASHER (96906) MS45904-72	EA	3

SECTION III. BASIC ISSUE ITEMS

(1) ILLUS NO.	(2) NATIONAL STOCK NUMBER	(3) DESCRIPTION (FSCM) AND PART NUMBER	(4) U/M USABLE ON CODE	(5) QTY REQD
		NO BASIC ISSUE ITEMS		

APPENDIX E EXPENDABLE SUPPLIES AND MATERIALS LIST

Section 1. INTRODUCTION

E-1. Scope

This appendix lists expendable supplies and materials you will need to operate and maintain the F-1461/VRC. These items are authorized to you by CTA 50-970, Expendable Items (Except Medical, Class V, Repair Parts, and Heraldic Items).

E-2. Explanation of Columns

a. Column 1 - Item Number. This number is assigned to the entry in the listing and is referenced in the narrative instructions to identify the material (e.g., Use cleaning compound, item 5, appx D).

b. Column 2 - Level. This column identifies the lowest level of maintenance that requires the listed item.

C - Operator/Crew
O - Organizational Maintenance
F - Direct Support Maintenance
H - General Support Maintenance

c. Column 3, National Stock Number. This is the National stock number assigned to the item; use it to request or requisition the item.

d. Column 4, Description. Indicates the Federal item name and, if required, a description to identify the item. The last line for each item indicates the part number followed by the Federal Supply Code for Manufacturers (FSCM) in parentheses, if applicable.

e. Column 5, Unit of Measure (U/M). Indicates the measure used in performing the actual maintenance function. The measure is expressed by a two-character alphabetical abbreviation (e.g., ea. in, pr). If the unit of measure differs from the unit of issue, requisition the lowest unit of issue that will satisfy your requirements.

SECTION II. EXPENDABLE SUPPLIES AND MATERIALS LIST

(1) ITEM NUMBER	(2) LEVEL	(3) NATIONAL STOCK NUMBER	(4) DESCRIPTION	(5) U/M
1	O	5340-00-906-3666	BRUSH, SOFT BRISTLE 153350 (01099)	EA
2	O	8309-00-267-3015	CLOTH, COTTON CHEESECLOTH, 36 INCHES WIDE CCC-C-440 (81348)	YD
3	O	6850-00-105-3084	TRICHLOROTRIFLUOROETHANE OT620 (18845)	FT
4	O	8010-00-582-5318	PRIMER, ZINC CHROMATE (81348)	QT
5	O	8010-00-111-7937	ENAMEL, FOREST GREEN, HEAT REFLECTING (solar) MIL-E-52798E	GA

CAPACITOR COLOR CODE TABLES

TABLE I - For use with Group 1, Styles CM, CN, CY, and CB

COLOR	MIL ID	1st SIG FIG	2nd SIG FIG	MULTIPLIER ¹	CAPACITANCE TOLERANCE				CHARACTERISTIC ²				DC WORKING VOLTAGE	OPERATING TEMP. RANGE	VIBRATION GRADE
					CM	CN	CY	CB	CM	CN	CY	CB			
BLACK	CM, CY CB	0	0	1			± 20 %	± 20 %		A				55 ° to + 70 °C	10 - 55 cps
BROWN		1	1	10						B	E	B			
RED		2	2	100	± 2 %		± 2 %	± 2 %		C		C		-55 ° to + 85 °C	
ORANGE		3	3	1,000		± 30 %				D			300		
YELLOW		4	4	10,000						E		D		-55 ° to + 125 °C	10 - 200 cps
GREEN		5	5		± 5 %					F			500		
BLUE		6	6											-55 ° to + 150 °C	
PURPLE (VIOLET)		7	7												
GREY		8	8												
WHITE		9	9												
GOLD				0.1			± 5 %	± 5 %							
SILVER	CN				± 10 %	± 10 %	± 10 %	± 10 %							

TABLE 11 - For use with Group 11, General Purposes, Style CK

COLOR	TEMP. RANGE AND VOLTAGE - TEMP LIMITS ³	1st SIG FIG	2nd SIG FIG	MULTIPLIER ¹	CAPACITANCE TOLERANCE	MIL ID
BLACK		0	0	1	± 20 %	
BROWN	AW	1	1	10	± 10 %	
RED	AX	2	2	100		
ORANGE	BX	3	3	1,000		
YELLOW	AV	4	4	10,000		CK
GREEN	CZ	5	5			
BLUE	BV	6	6			
PURPLE (VIOLET)		7	7			
GREY		8	8			
WHITE		9	9			
GOLD						
SILVER						

TABLE 111 - For use with Group 111, Temperature Compensating, Style CC

COLOR	TEMPERATURE COEFFICIENT ⁴	1st SIG FIG	2nd SIG FIG	MULTIPLIER ¹	CAPACITANCE TOLERANCE		MIL ID
					CAPACITANCES OVER 10uuf	CAPACITANCES 10uuf OR LESS	
BLACK	0	0	0	1		± 2.0uuf	CC
BROWN	-30	1	1	10	± 1 %		
RED	-80	2	2	100	± 2 %	± 0.25uuf	
ORANGE	-150	3	3	1,000			
YELLOW	-220	4	4				
GREEN	-330	5	5		± 5 %	± 0.5uuf	
BLUE	-470	6	6				
PURPLE (VIOLET)	-750	7	7	0.01			
GREY		8	8	0.1	± 10 %		
WHITE		9	9				
GOLD	+100					± 1.0uuf	
SILVER							

1. The multiplier is the number by which the two significant (SIG) figures are multiplied to obtain the capacitance in uuf.
2. Letter indicate The Characteristics designated in applicable specification: MIL -C-5, NUL -C-9I, MIL -C-11272 and MIL C-10950 respectively.
3. Letters indicate the temperature range and voltage -temperature limits designated in MIL -C-1 1015.
4. Temperature coefficient in parts per million per degree centigrade.

COLOR CODE MARKING FOR MILITARY STANDARD CAPACITORS

GROUP I Capacitors, Fixed, Various- Dielectrics, Styles CM, CN, CY, and CB

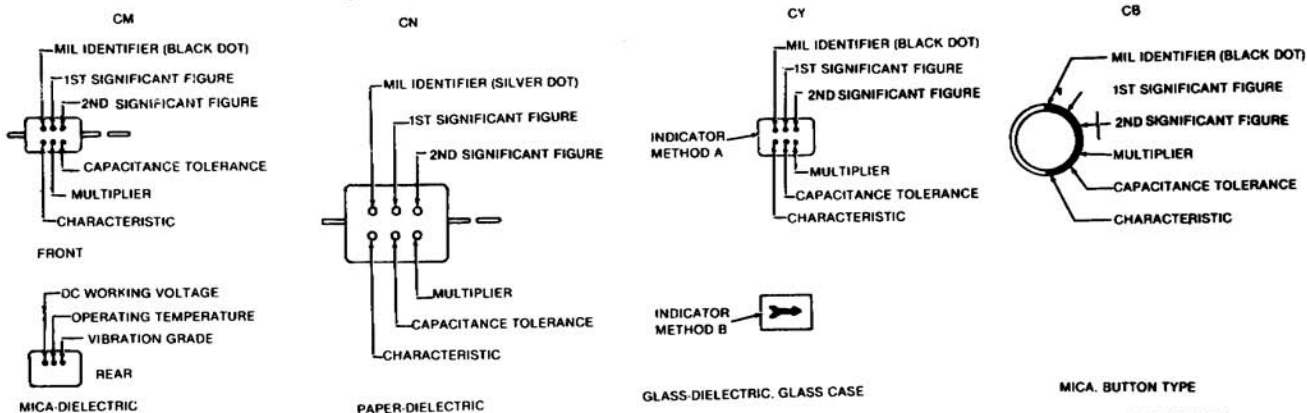

GROUP II Capacitors, Fixed, Ceramic-Dielectric (General Purpose) Style CK

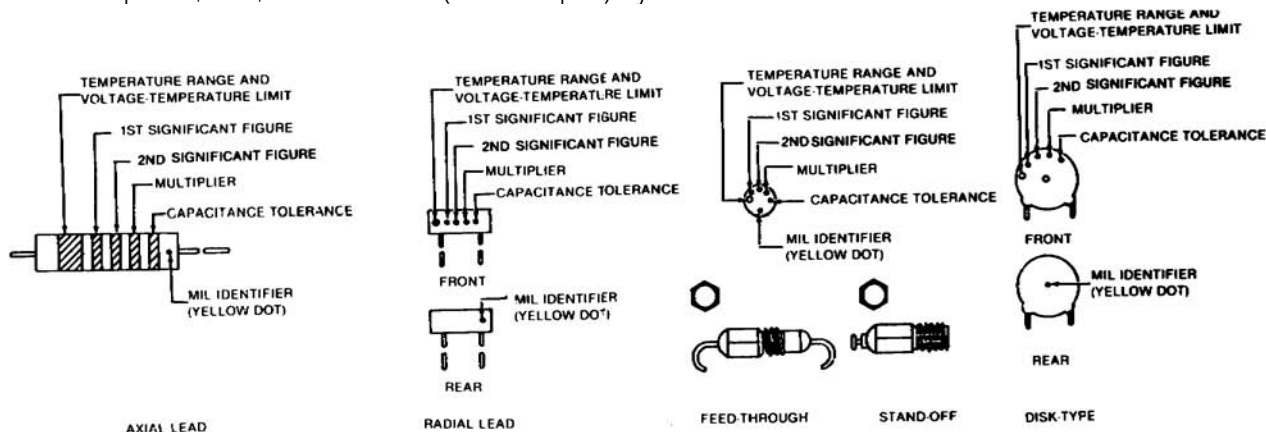

GROUP III Capacitors, Fixed, Ceramic-Dielectric (Temperature Compensating) Style CC

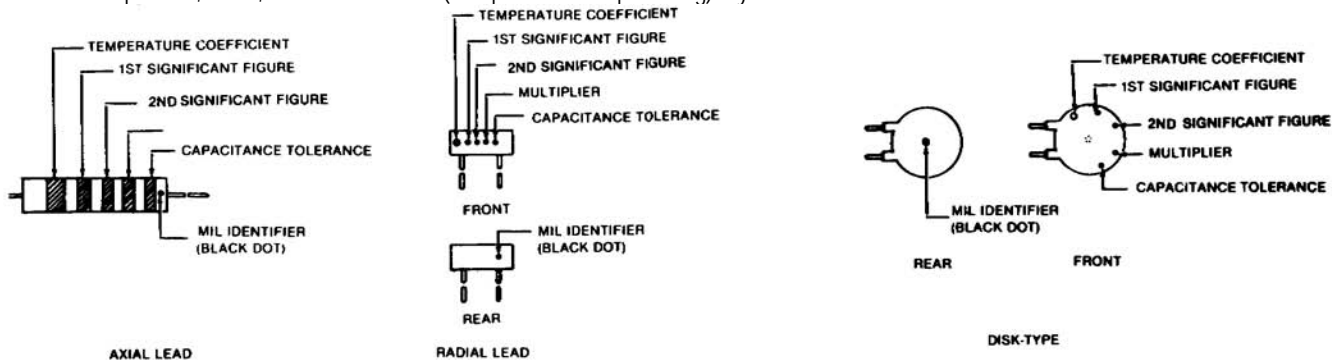

FIGURE FO-1. COLOR CODE MARKING FOR MILITARY STANDARD RESISTORS AND INDUCTORS (SHEET 1 OF 2).

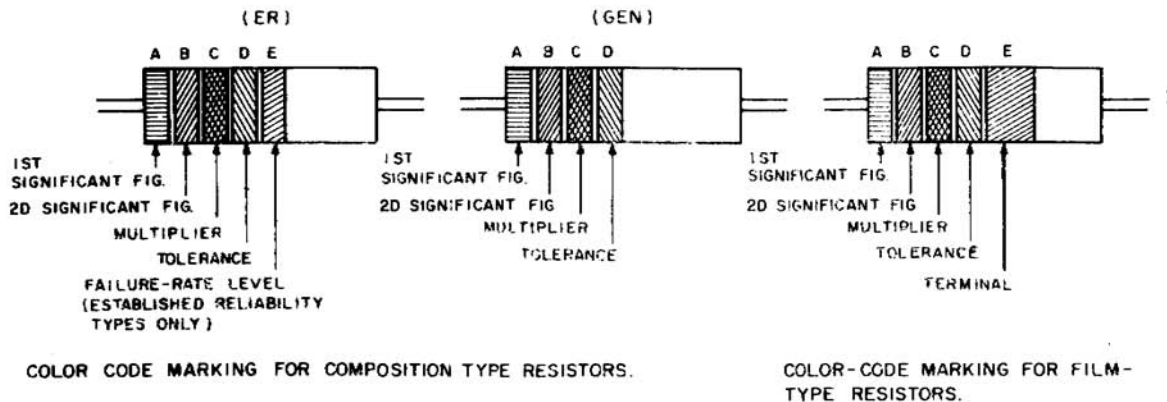

TABLE I
COLOR CODE FOR COMPOSITION TYPE AND FILM TYPE RESISTORS.

BAND A		BAND B		BAND C		BAND D		BAND E		
COLOR	FIRST SIGNIFICANT FIGURE	COLOR	SECOND SIGNIFICANT FIGURE	COLOR	MULTIPLIER	COLOR	RESISTANCE TOLERANCE (PERCENT)	COLOR	FAILURE RATE LEVEL	TERM.
BLACK	0	BLACK	0	BLACK	1			BROWN	M=1.0	SOLD-ERABLE
BROWN	1	BROWN	1	BROWN	10			RED	P=0.1	
RED	2	RED	2	RED	100			ORANGE	R=0.01	
ORANGE	3	ORANGE	3	ORANGE	1,000			YELLOW	S=0.001	
YELLOW	4	YELLOW	4	YELLOW	10,000	SILVER	±10 (COMP TYPE ONLY)	WHITE		
GREEN	5	GREEN	5	GREEN	100,000	GOLD	±5			
BLUE	6	BLUE	6	BLUE	1,000,000	RED	±2 (NOT APPLICABLE TO ESTABLISHED RELIABILITY).			
PURPLE (VIOLET)	7	PURPLE (VIOLET)	7							
GRAY	8	GRAY	8	SILVER	0.01					
WHITE	9	WHITE	9	GOLD	0.1					

BAND A - THE FIRST SIGNIFICANT FIGURE OF THE RESISTANCE VALUE (BANDS A THRU D SHALL BE OF EQUAL WIDTH.)

BAND B - THE SECOND SIGNIFICANT FIGURE OF THE RESISTANCE VALUE.

BAND C - THE MULTIPLIER (THE MULTIPLIER IS THE FACTOR BY WHICH THE TWO SIGNIFICANT FIGURES ARE MULTIPLIED TO YIELD THE NOMINAL RESISTANCE VALUE.)

BAND D - THE RESISTANCE TOLERANCE.

BAND E - WHEN USED ON COMPOSITION RESISTORS BAND E INDICATES ESTABLISHED RELIABILITY FAILURE RATE LEVEL (PERCENT FAILURE PER 1,000 HOURS) ON FILM RESISTORS. THIS BAND SHALL BE APPROXIMATELY 1/2 TIMES THE WIDTH OF OTHER BANDS, AND INDICATES TYPE OF TERMINAL RESISTANCES IDENTIFIED BY NUMBERS AND LETTERS (THESE ARE NOT COLOR CODED)

SOME RESISTORS ARE IDENTIFIED BY THREE OR FOUR DIGIT ALPHA NUMERIC DESIGNATORS. THE LETTER R IS USED IN PLACE OF A DECIMAL POINT WHEN FRACTIONAL VALUES OF AN OHM ARE EXPRESSED. FOR EXAMPLE:

$$2R7 - 2.7 \text{ OHMS } 10R0 = 10.0 \text{ OHMS}$$

FOR WIRE-WOUND-TYPE RESISTORS COLOR CODING IS NOT USED IDENTIFICATION MARKING IS SPECIFIED IN EACH OF THE APPLICABLE SPECIFICATIONS.

A. COLOR CODE MARKING FOR MILITARY STANDARD RESISTORS

EXAMPLES OF COLOR CODING

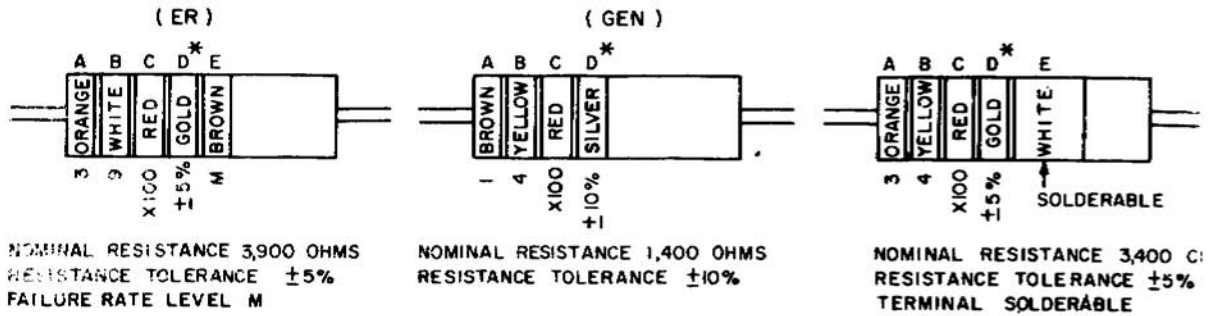

COMPOSITION-TYPE RESISTORS

FILM-TYPE RESISTORS

* IF BAND D IS OMITTED, THE RESISTOR TOLERANCE IS $\pm 20\%$ AND THE RESISTOR IS NOT MIL-STD.

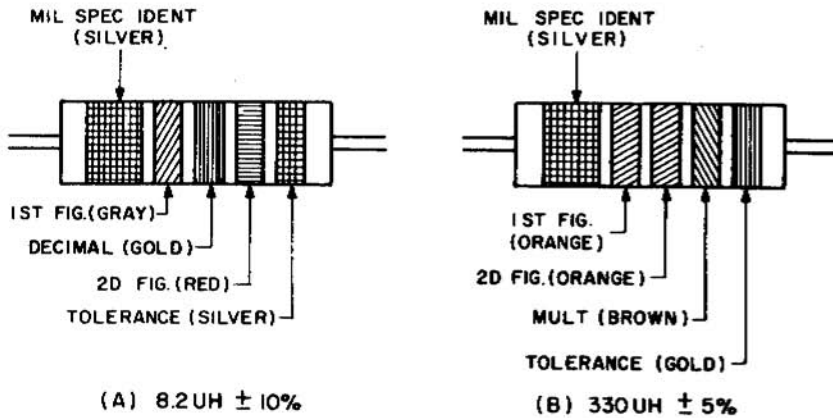

COLOR CODING FOR TUBULAR ENCAPSULATED R.F. CHOKES. AT A, AN EXAMPLE OF OF THE COODING FOR AN 8.2 UK CHOKE IS GIVEN. AT B, THE COLOR BANDS FOR A 330 UH INDUCTOR ARE ILLUSTRATED

TABLE 2
COLOR CODING FOR TUBULAR ENCAPSULATED R.F.. CHOKES.

COLOR	SIGNI-FICANT FIGURE	MULTIPLIER	INDUCTANCE TOLERANCE (PERCENT)
BLACK	0	1	
BROWN	1	10	1
RED	2	100	2
ORANGE	3	1,000	3
YELLOW	4		
GREEN	5		
BLUE	6		
VIOLET	7		
GRAY	8		
WHITE	9		
NONE			20
SILVER			10
GOLD	DECIMAL POINT		5

MULTIPLIER IS THE FACTOR BY WHICH THE TWO COLOR FIGU RES ARE MULTIPLIED TO OBTAIN THE INDUCTANCE VALUE OF THE CHOKE COIL.

RECOMMENDED CHANGES TO EQUIPMENT TECHNICAL PUBLICATIONS

SOMETHING WRONG WITH PUBLICATION



THEN...JOT DOWN THE DOPE ABOUT IT ON THIS FORM. CAREFULLY TEAR IT OUT, FOLD IT AND DROP IT IN THE MAIL.

FROM: (PRINT YOUR UNIT'S COMPLETE ADDRESS)

DATE SENT

PUBLICATION NUMBER

PUBLICATION DATE

PUBLICATION TITLE

BE EXACT PIN-POINT WHERE IT IS

PAGE NO.	PARA-GRAPH	FIGURE NO.	TABLE NO.

IN THIS SPACE, TELL WHAT IS WRONG AND WHAT SHOULD BE DONE ABOUT IT.

TEAR ALONG PERFORATED LINE

PRINTED NAME, GRADE OR TITLE AND TELEPHONE NUMBER

SIGN HERE

By Order of the Secretary of the Army:

Official:

ROBERT M. JOYCE

Major General, United States Army

The Adjutant General

JOHN A. WICKHAM JR.

General, United States Army

Chief of Staff

DISTRIBUTION:

To be distributed in accordance with special list.